



mecalr PR 1/4"

# PILOT VALVE

# MECAIR PILOT VALVE

PR 1/4"



## DESCRIPTION

The **PR 1/4" single remote solenoid pilot** has been designed for the control of VEM type diaphragm valves. PR 1/4" can be installed on the interior wall of any control box or external part of the filter, located near the diaphragm valves. To install the PR 1/4" it is necessary to drill a hole of 18.5 mm DN in the control box wall, leaving the pneumatic connection (PR 1/4") outside the box. Anchor the solenoid pilot to the wall with the locknut. The pneumatic connection to the remotely piloted diaphragm valve is made with pneumatic pipe with an OD of 8 mm. The pneumatic pipe should not exceed a maximum length of 2 metres to ensure correct functioning of the pilot valve. The electrical connection is made inside the box by way of an IP65 connector with PG9 cable entry.

The PR 1/4" solenoid pilot body is manufactured in brass and is available with solenoids with a full range of voltages.

**Upon request** the solenoid is also available in accordance with the ATEX Directive 94/9/CE, Zone 22 (Dust).

The PR 1/4" is available with solenoid – 24DCX

(24 V DC/12 W) and DIN socket PLG11-ATEX

## GENERAL CHARACTERISTICS

Valve connection	1/4" Gas
Operating pressure	From 0.5 to 7.5 bar
Exhaust	1/8" Gas

## CONSTRUCTION FEATURES – ENCLOSURE

Pilot body	Brass
Ferrule	Brass
Locknut	Zinc coated
O-ring	NBR

## ELECTRICAL CHARACTERISTICS

Isolation class	Class H
Connector	Pg9
Standard connector	EN175301 - 803 / A/ISO 4400
Optional connector	Conf. Dir. 94/9/CE ATEX II 3GD T6
Isolation class connector	VDE 0110 - 1/89
Electrical protection	IP65 EN60529
Voltages	12V DC (supply +10% max.) 18 W 24 V DC (supply +10% max.) 18 W 48V DC (supply +10% max.) 18 W 110 V DC (supply +10% max.) 18 W 24 V 50/60 Hz (supply +10% max.) 38/31 VA 48 V 50/60 Hz (supply +10% max.) 41/32 VA 115 V 50/60 Hz (supply +10% max.) 63/53 VA 220/240 V 50/60 Hz (supply +10% max.) 46/37 VA
Ambient temperature	-20°C/+60°C

## HOW TO ORDER

**Part Number Code:** **PR 1/4" - 110/50**

**Remote pilot** (points to PR)

**Inlet 1/4" Gas** (points to 1/4")

**Voltage and frequency** (points to 110/50)

# MECAIR PILOT VALVE

PR 1/4"

## DIMENSIONS (mm)

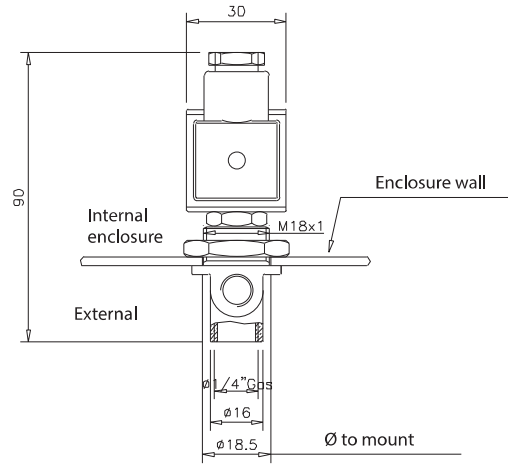
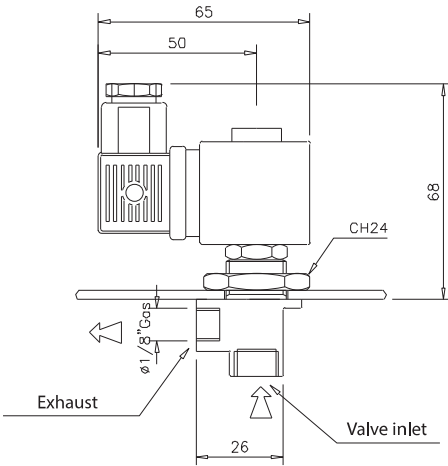

## EXPLODED VIEW - PILOT

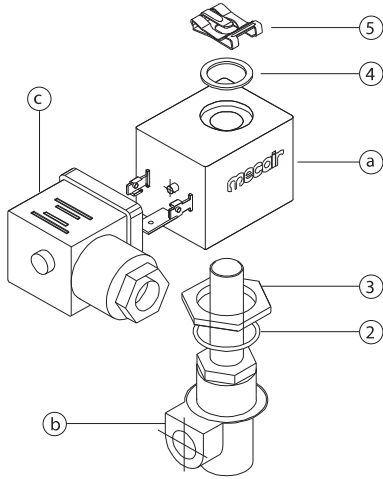

POS.	DESCRIPTION	CODE
	a) Solenoid (*)	a) KIT SB4 - ../.. (*)
	b) Ferrule	b) KIT PR 1/4
	c) DIN connector EN175301 - 803 IP65	c) KIT PLG9
2	O-ring OR2081	KIT M330013
3	Locknut M18 x 1	KIT M540028
4	Nylon seal Ø 17 sp. 2	KIT M530100
5	Fixing clip	KIT G690586

(\*) Specify voltage.

## EXAMPLE OF ASSEMBLY APPLICATION

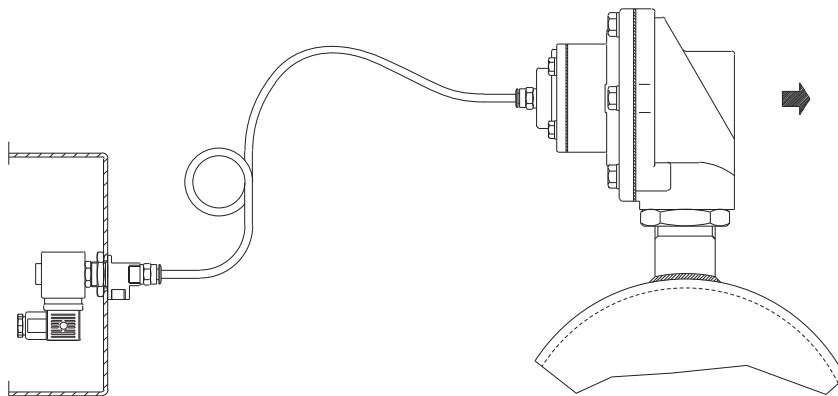



CLEANAIRSYSTEMS.COM

© 2014 Pentair Clean Air Systems reserves the right to change product designs and specifications without notice.